

Operator's Manual SUPPLEMENT

MANCO MODEL NO. 580-00

WARNING:
Read Engine
Owner's Manual,
Vehicle Operator's
Manual, and
Supplement
Carefully Before
Operating
Vehicle.

**Assembly
Operation
Maintenance
Warranty**



**THIS VEHICLE IS FOR
OFF-ROAD USE ONLY**

MANCO
PRODUCTS, INC.

4404 Engle Ridge Drive Ft. Wayne, Indiana 46804 219-432-1596

BEFORE OPERATING THIS VEHICLE, THE OWNER AND/OR OPERATOR MUST UNDERSTAND THE VEHICLE WAS NOT DESIGNED OR MANUFACTURED TO MEET SPECIFICATIONS FOR USE ON PUBLIC ROADS, STREETS, HIGHWAYS, OR THOROUGHFARES AND HAVE READ AND HAVE AN UNDERSTANDING OF ALL THE INSTRUCTIONS FOR SAFE ASSEMBLY AND OPERATION AS WELL AS THE INSTRUCTIONS GOVERNING THE ENGINE AND OTHER PORTIONS OF THE VEHICLE.

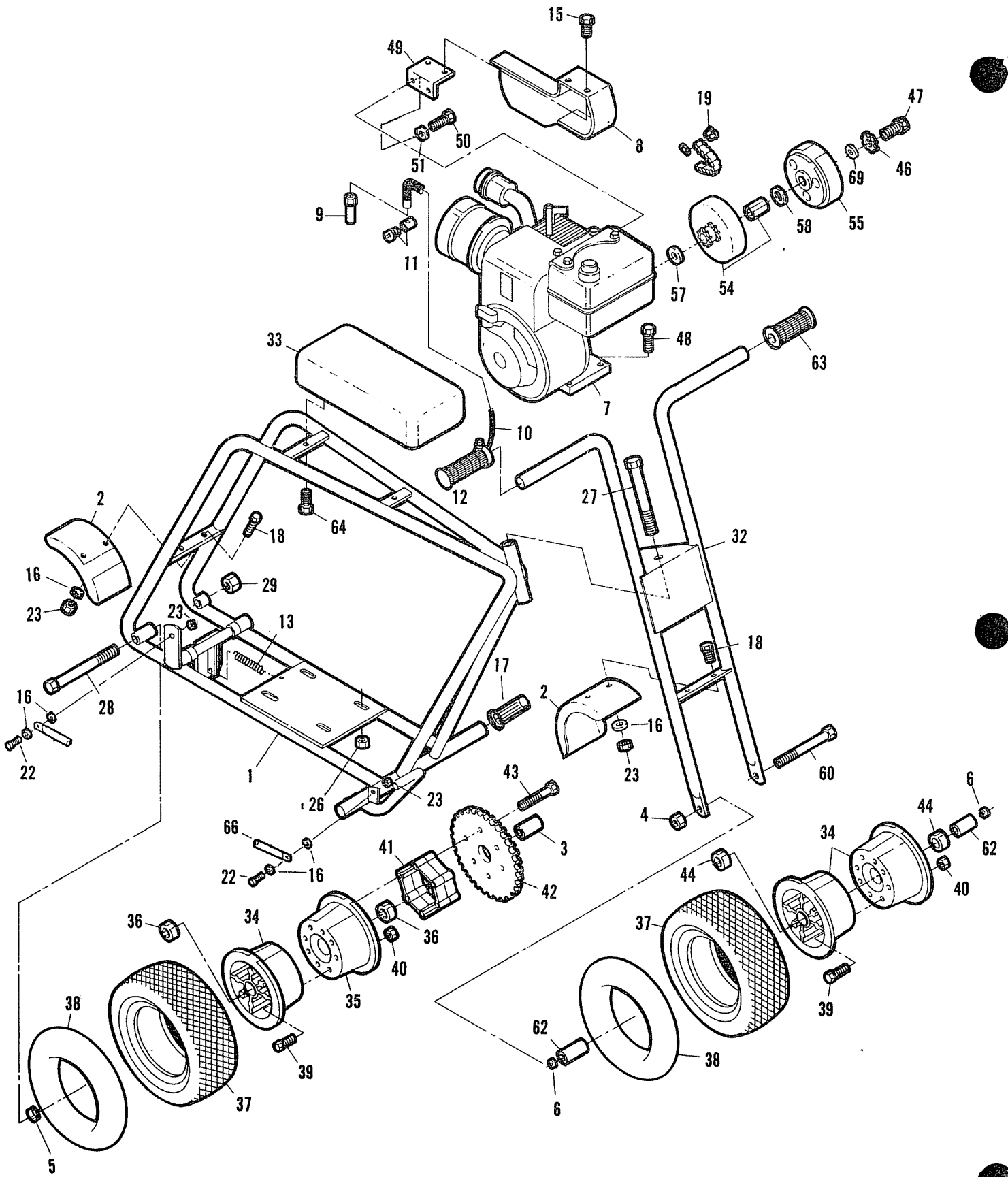

REPAIR PARTS

Model 580-00

REF. NO.	PART NO.	DESCRIPTION	REF. NO.	PART NO.	DESCRIPTION
1	1988-19	Frame Asm	37	2246	4.10/3.50 x 5" Stud Tire
2	2018-2	Fender	38	1753	5" Inner Tube
3	2019	Wheel Spacer, 1 3/4"	39	5839	1/4-20 x 3/4 Hex Cap Screw, Whizlock
4	1046	5/8-11 Hex Locknut	40	1186	1/4-20 Whizlock Nut
5	3761	Spacer — 5/8ID x 1/4"	41	8008	Sprocket Spacer
6	1650	5/8 Flat Washer	42	8007	Sprocket
ASM	2245	Wheel Assembly, 5" Rear, ref. # 34-43	43	9127	5/16-18 x 2 1/4 Hex Cap Screw
ASM	2280	Chain w/Masterlink	44	1419	Bearing
ASM	4199	Twist Grip Asm	46	1130	3/8 Split Lockwasher
7	4186	Engine — 3.5 H.P., Tecumseh	47	9073	3/8-24 x 3/4 Hex Cap Screw
8	PX2297	Chainguard	48	1122	5/16-18 x 1 1/2 Hex Cap Screw
9	1628	Cable Retainer	49	PX2289	Bracket
10	5874	Cable and Housing	50	9101	5/16-24 x 1/2 Hex Cap Screw
11	1018	Cable Stop w/Screw	51	9030	5/16 Interlock Washer
12	1013	Twist Grip	ASM	4335	Clutch Assembly
13	5070	Extension Spring	54	4491	Drum Assembly
NI	1019	TyWrap	55	4496	Clutch Center
15	PX2304	No. 14 Screw	57	1168	Washer 3/4 I.D. x 1" O.D.
16	1854	No. 14 Flat Washer	58	3146	Fiber Washer
17	2274	Grip	60	1138	5/8-11 x 7 Hex Cap Screw
18	5839	1/4-20 x 3/4 Hex Cap Screw w/Flange	62	4266	Wheel Spacer — 1 1/2"
19	1269	Masterlink	63	1014	Dummy Grip
22	1846	1/4-20 x 3/4 Hex Cap Screw	64	9006	1/4-20 x 1/2 Hex Flanged Whizlock Screw
23	9057	1/4-20 Locknut	66	4986-2	Brake Rod
26	1263	5/16-18 Hex Flanged Whizlock Nut	69	9125	3/8 Flat Washer
27	1138	5/8-11 x 7 Hex Cap Screw	NI	1971	Brake Pedal Grip
28	2772	5/8-11 x 9 1/2 Hex Cap Screw	NI	3745	Stopswitch Assembly
29	1046	5/8-11 Hex Locknut	NI	4198	Operator's Manual — Mini-Bike
ASM	2247	Wheel Assembly, 5" Front, ref. # 34, 37-40, 44	NI	4197	Operator's Manual Supplement — 580
32	2038-19	Fork			
33	2042	Seat			
34	8004	Wheel Half, 5" Untapped			
35	8006	Wheel Half, 5" Tapped			
36	1093	Bearing			

THIS SYMBOL POINTS OUT IMPORTANT SAFETY INSTRUCTIONS WHICH IF NOT FOLLOWED COULD ENDANGER THE PERSONAL SAFETY OF OPERATOR AND OTHERS. READ AND FOLLOW ALL INSTRUCTIONS IN THIS SUPPLEMENT AS WELL AS THE OPERATOR'S MANUAL AND THE ENGINE MANUAL BEFORE ATTEMPTING TO OPERATE THIS VEHICLE.

 **WARNING** — The following are special assembly and maintenance instructions specifically for the Manco mini-bike model no. 580-00.

ASSEMBLY

1. Fasten the seat (ref. no. 33) to the frame (ref. no. 1) using the two ¼-20 x ½ Hex Flanged Whizlock Screws (ref. no. 64). Tighten securely.

MAINTENANCE

1. The brake rod should be adjusted (effectively shortened), if the brake pad does not press hard enough against the tire to stop the vehicle.
2. To adjust the brake, shorten the brake rod to be removing the fastener through its forward end, then reassemble the connection by using the next hole toward the rear.

 **WARNING** — Do not overtighten fasteners. Pedal must move freely.

3. Additional adjustment can be made in a similar manner, to vehicles with a scrub brake, at the rear of the brake rod where it attaches to the brake lever.

 **WARNING** — Ensure proper fasteners in good condition are installed throughout brake system. Failure of these fasteners may cause brake failure.

**THIS VEHICLE IS FOR
OFF-ROAD USE ONLY**